

2.1 WD615发动机（E2）/Engine

序号/ No.	名 称 / Designation	页 码 / Page No.
2.1.01	发动机总成/Engine	1
2.1.02	气缸体总成/Cylinder Block Ass	2
2.1.03	气缸体装配件/Parts in cylinder Block	3
2.1.04	齿轮室/Gear case	4
2.1.05	飞轮壳、油气分离器/Fly wheel housing & Oil separator	6
2.1.06	曲轴及飞轮/Crankshaft and Flywheel	8
2.1.07	连杆与活塞/Connecting Rod and Piston	9
2.1.08	气缸盖/Cylinder Head	10
2.1.09	配气机构/Valve-Gear Mechanism	12
2.1.10	冷却系统/Cooling System	14
2.1.11	机油泵和机油滤清器/Oil Pump and Oil Filter	16
2.1.12	供油系/Fuel Supply System	18
2.1.13	燃油滤清器部分(M+H)/Fuel Filter	21
2.1.14	电机及传感器/Alternator、Starter & Sensor	22
2.1.15	进排气系统/ Intake Manifold and Exhaust Manifold	23
2.1.16	双缸空压机/Compressor	27
2.1.17	油底壳/Oil Pan	29

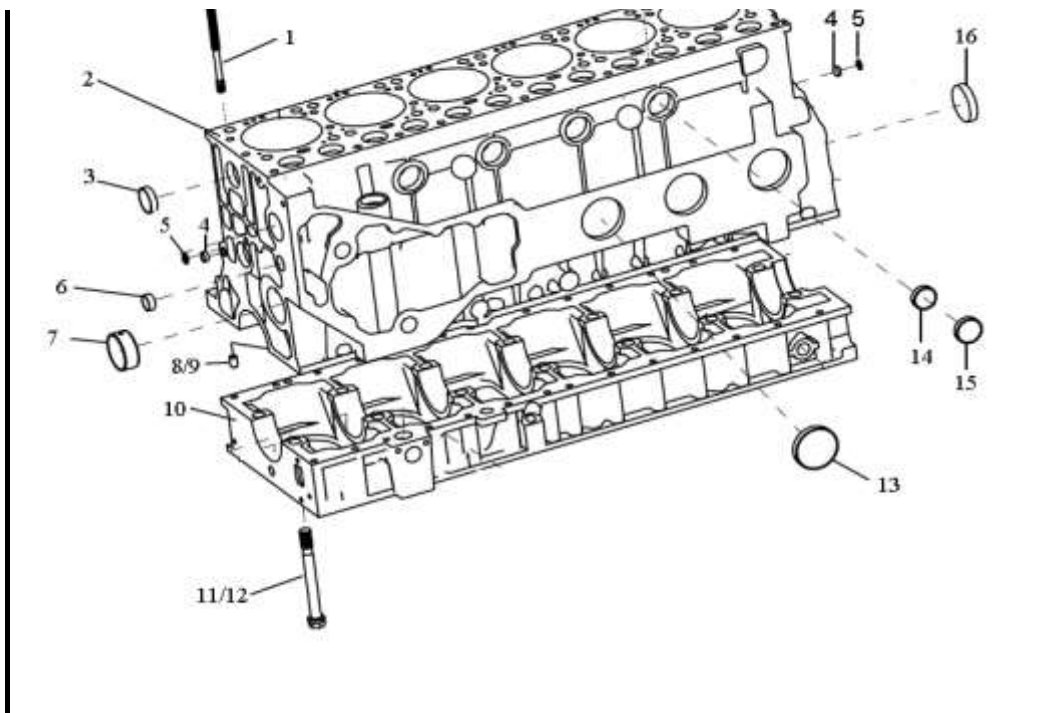

2.1.02 气缸体总成/Cylinder Block Ass

序号 No.	零部件图号 Part No.	名称	Part Name	数量 Qty	备注 Remark
0	AZ1095010048	气缸体总成	Cylinder block asse.	1	Incl. 1-16
1	VG1500010185	气缸盖螺栓	Stud	21	
2	61500010356B/1	气缸体	Cylinder block	1	
3	190003982121	碗形塞	Core plug	4	
4	190003989480	碗形塞	Core plug	2	
5	VG407010046	密封圈	Washer	2	
6	190003989204	碗形塞	Core plug	1	
7	VG1560010029	凸轮轴衬套	Camshaft bush	5	
7a	VG1096010010A	凸轮轴衬套	Camshaft bush	1	
8	90003901604A	圆柱销	Cylinder pin	2	
9	Q5211220	圆柱销	Cylinder pin	1	
10	161500010366G/	曲轴箱	Crankcase	1	
11	VG14010114	主轴承螺栓	Screw	13	
12	VG14010217	主轴承螺栓	Screw	1	
13	190003989210	碗形塞	Core plug	6	
14	190003989289	碗形塞	Core plug	4	
15	190003989215	碗形塞	Core plug	3	
16	190003989288	碗形塞	Core plug	1	

2.1.03 气缸体装配件/Parts in cylinder Block



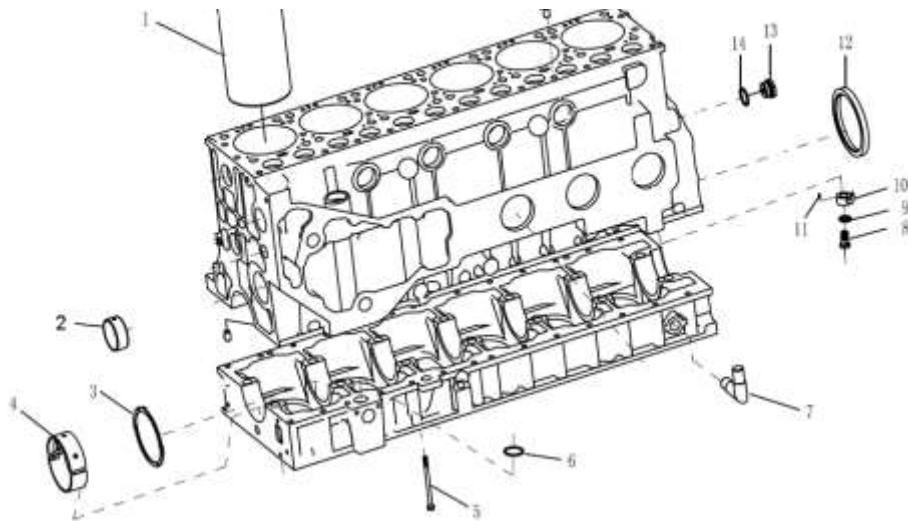

2.1.03 气缸体装配/Parts in cylinder Block

序号 No.	零部件图号 Part No.	名称	Part Name	数量 Qty	备注 Remark
1	VG1540010006	气缸套	Cylinder liner	6	
2	VG2600010990	凸轮轴衬套	Camshaft bush	1	
3	VG1500010125	止推片付	Stop washer pair	2	
4	VG1500010046	主轴瓦付	Bearing shell pair	7	
5	190003802493	六角头螺栓	Screw	27	
6	VG1400010032	密封圈	Washer	2	
7	VG2600070097	回油弯管	Pipe	1	
8	190003962621	空心螺栓	Female Screw	6	
9	VG9003080005	复合密封垫圈	Washer	6	
10	VG2600010659	喷嘴总成用于47、69机	Spraying nozzle asse.for WD615.47/69	6	
11	190003909603	弹性圆柱销	Spring cylinder pin	6	
12	VG1047010050	后油封总成(迷宫式)	Gasket(back)	1	
13	VG1460070011	主油道后螺塞	Plug	1	
14	VG2600010735	复合垫圈	Washer	2	
15	190003909626	弹性圆柱销	Spring cylinder pin	6	
16	190003901604	圆柱销	Cylinder pin	6	

2.1.04 齿轮室/Gear case

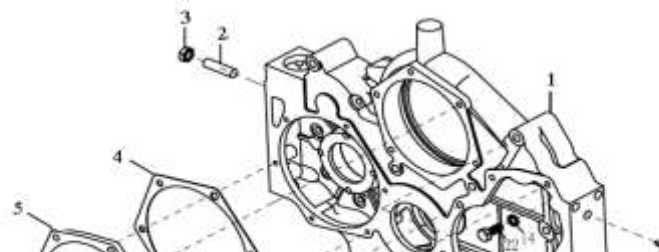

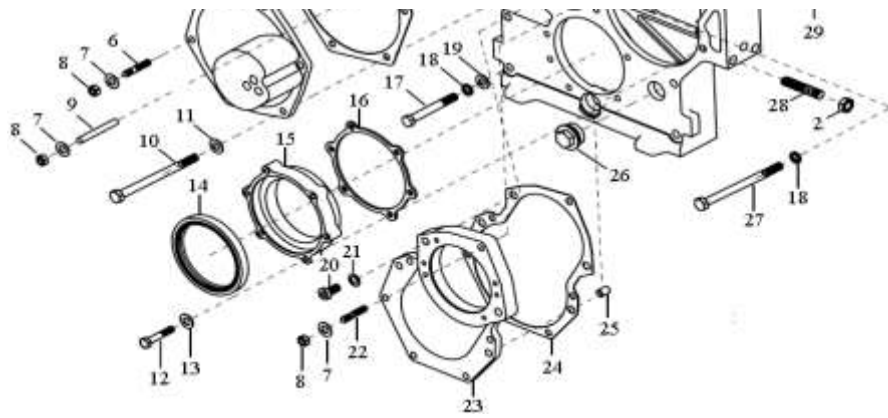

2.1.04 齿轮室/Gear case

序号 No.	零部件图号 Part No.	名称	Part Name	数量 Qty	备注 Remark
1	61557010008A	双缸空压机正时齿轮室	Gear case	1	
2	Q1201245F3	双头螺柱	Stud	2	
3	190003888453	螺母	Nut	8	
4	VG14010040	空压机齿轮盖垫片	Gasket	1	
5	VG2600010830	空压机齿轮盖	Compressor gear cover	1	
6	190003813429	双头螺柱	Stud	14	
7	190003932023	波形弹性垫圈	Spring washer	19	
8	190003871252	1型六角螺母	Nut	17	
9	190003813467	双头螺柱	Stud	2	
10	190003802576	六角头螺栓	Screw	1	
11	190003932024	波形弹性垫圈	Spring washer	1	
12	190011260039	六角头螺栓	Screw	6	
13	VG9003080001	复合密封垫圈	Washer	6	
14	VG1047010038	前油封	Oil sealing(front)	1	
15	VG2600010928	前油封座	Oil sealing seat (front)	1	
16	VG2600010934	前油封座垫片	Gasket (front)	1	
17	190003800571	六角头螺栓	Screw	1	
18	190003931122	弹簧垫圈	Spring washer	10	
19	190003930271	平垫圈	Washer	2	
20	190003862524	内六角圆柱头螺钉	Screw	2	
21	190003932025	鞍形弹性垫圈	Spring washer	2	

2.1.04 齿轮室/Gear case

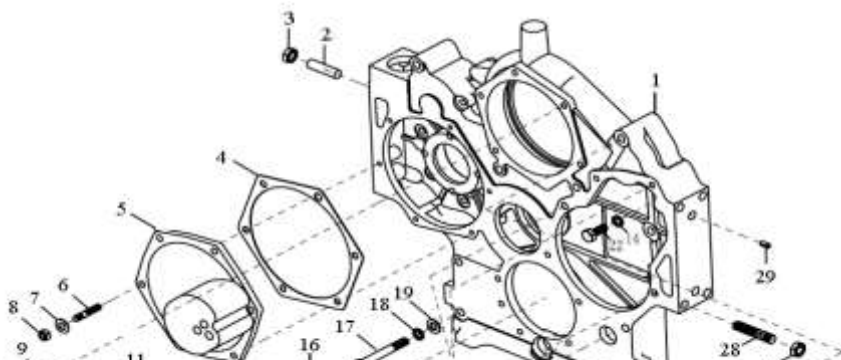

2.1.05 飞轮壳、油气分离器/Fly wheel housing & Oil separator

序号 No.	零部件图号 Part No.	名称	Part Name	数量 Qty	备注 Remark
1	VG12G00040038	带纤维夹层的橡胶软管	Hose	1	
2	190003989336	软管卡箍	Hose clip	1	
3	VG1095010050	油气分离器总成	Oil separator	1	
4	Q734B2650265	O形橡胶密封圈	O-ring	1	
5	VG1095010040	加油短管组件	Oil pipe	1	
6	VG14010086	加油短管垫片	Gasket	1	
7	190003802321	六角头螺栓	Screw	5	
8	190003931082	轻型弹簧垫圈	Spring washer	5	
9	VG1540010015B	机油冷却器盖垫片	Gasket	1	
10	VG1540010014B	机油冷却器盖	Cover	1	
11	VG9003080005	复合密封垫圈	Washer	1	
12	190003962020	轻型六角头圆柱螺塞	Plug	1	
13	190003932023	波形弹性垫圈	Spring washer	40	
14	190003800467	六角头螺栓	Screw	7	
15	190003802437	六角头螺栓	Screw	6	
16	VG2600010705	机油尺管下组件	Oil dipstick-lower	1	
17	VG1500010600	油尺管上组件总成	Oil dipstick-upper	1	
18	VG1800210011	观察孔盖	Inspector cover	1	
19	190003802511	六角头螺栓	Screw	2	
20	190003901604	圆柱销	Cylinder pin	2	
21	VG1500010062	飞轮壳螺栓	Screw	7	
22	VG1500010101	飞轮壳螺栓	Screw	6	
23	VG9003813543	双头螺柱	Stud	10	

2.1.05 飞轮壳、油气分离器/Fly wheel housing & Oil separator

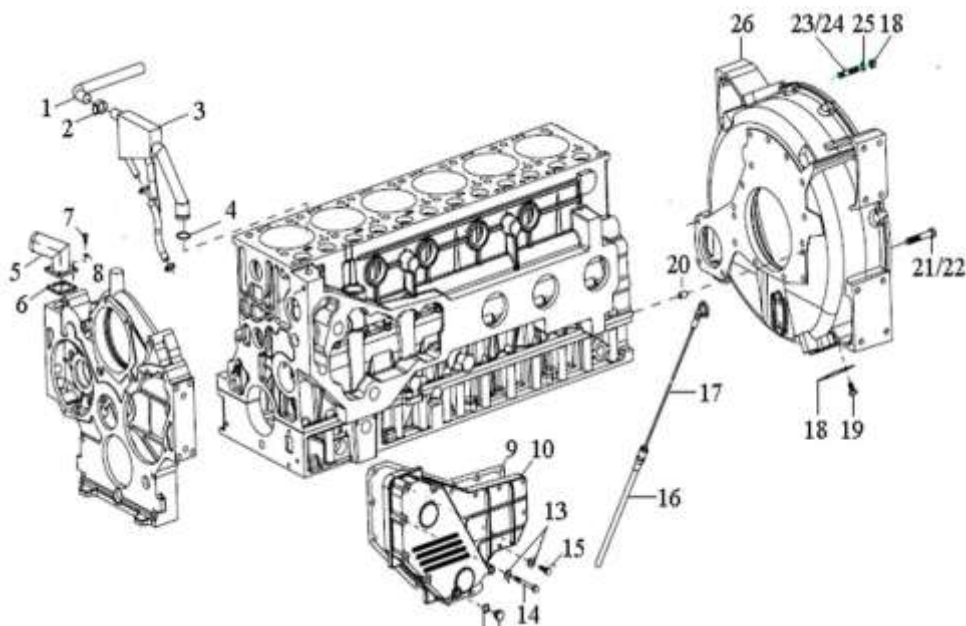

2.1.05 飞轮壳、油气分离器/Fly wheel housing & Oil separator

序号 No.	零部件图号 Part No.	名称	Part Name	数量 Qty	备注 Remark
24	190003813544	双头螺柱	Stud	2	
25	190003931122	弹簧垫圈	Spring washer	12	
26	AZ1500010012	飞轮壳	Fly wheel housing	1	
	VG2600010446	机油标尺的橡胶软管	Hose for oil dipsticle	1	
	VG2600010193	铭牌	Name plate	1	
	VG2600010791	标牌铆钉	Rivet	4	
	90003989301	软管卡箍	Clip	2	
	VG1095010034	带纤维夹层橡胶软管	Hose	1	
	VG2600010447	单管夹子	Clip	1	
	VG2600010445	单管夹子	Clip	1	
	VG288730061	O型密封圈	O seal ring	1	
	VG29135	转向泵封口	Seal	1	
	190003802419	六角头螺栓	Screw	2	
	190003932023	波形弹性垫圈	Spring washer	2	
	190003930261	平垫圈	Washer	1	
	190003800465	六角头螺栓	Screw	1	
	VG1500010005	垫块	Seat	2	
	190003989340	软管卡箍	Clip	1	
	VG609E110049	固定板	Plate	1	
	VG1540110211	支撑块	Block	2	

2.1.06 曲轴及飞轮/Crankshaft and Flywheel

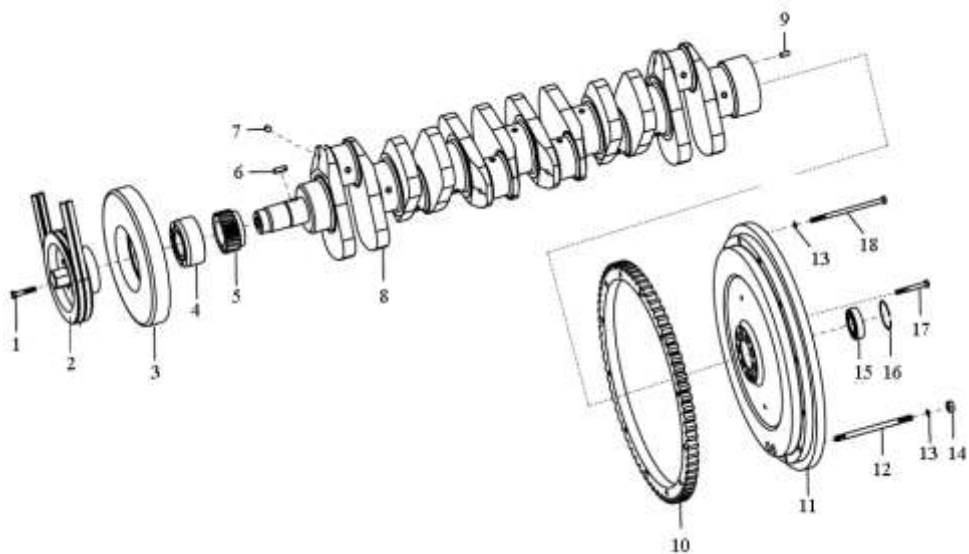

2.1.06 曲轴及飞轮/Crankshaft and Flywheel					
序号	零部件图号	名称	Part Name	数量	备注
No.	Part No.			Qty	Remark
1	190003802558	六角头螺栓	Screw	8	
2	VG1560020020	皮带轮	Belt pulley	1	
3	VG1540020003	减振器	Vibration damper	1	
—	161560020029	曲轴总成用于47、69机	Crankshaft ass.for WD615.47/69	1	Incl. 4-9
4	VG1500020070	法兰	Flange	1	
5	VG14020038	曲轴齿轮	Crankshaft gear	1	
6	Q5510828	普通平键	Key	1	
7	VG2600020311	油孔堵头	Plug	6	
8	161560020024	曲轴	WD615.47/69	1	
9	190003901418	圆柱销	Cylinder pin	1	
10	VG2600020208	飞轮齿圈	Flywheel ring gear	1	
11	AZ1092020002	飞轮WD615.69/87/62	WD615.69/87/62	1	
12	190003813571	双头螺柱	Stud	2	
13	190003932024	波形弹性垫圈	Spring washer	12	
14	190003871305	1型六角螺母	Nut	2	
15	190003311416	球轴承	Ball bearing	1	
16	190003934310	孔用弹性挡圈	Washer	1	
17	VG1500020046	六角头螺栓	Screw	9	
18	190003800579	六角头螺栓	Screw	10	

2.1.07 连杆与活塞/Connecting Rod and Piston

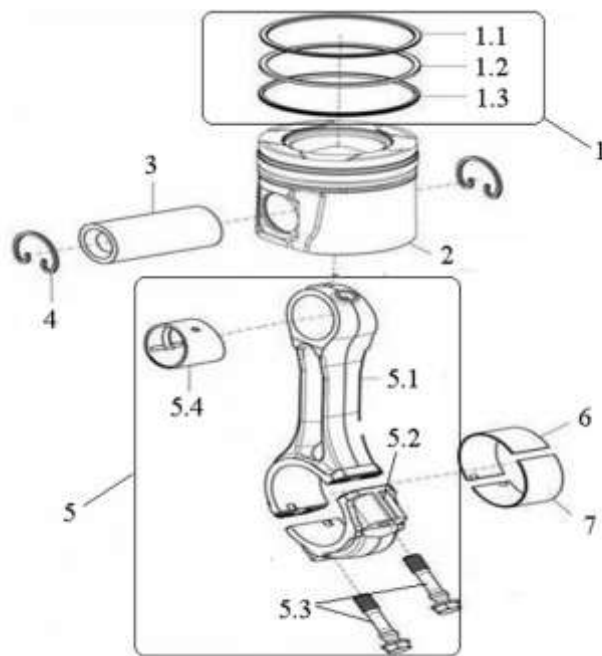

2.1.07 连杆与活塞/Connecting Rod and Piston

序号	零部件图号	名称	Part Name	数量	备注
----	-------	----	-----------	----	----

1,3	190003989277	碗形塞片12/8N05564 黄	Shim	6	
1,4	190003989725	碗形塞片25/8N05564 黄	Shim	6	
2	VG1200040027	夹紧块	Block	2	
3	VG1200040034	带肩螺母	Nut	21	
4	VG1200040023A	夹紧块	Block	5	
5	VG1560040032	气门杆密封套	Sleeve	12	
6	VG14040021	气缸盖罩衬垫	Gasket	6	
7	VG14040065	气缸盖罩	Cylinder head cover	6	
8	190003932023	波形弹性垫圈	Wave washer	12	
9	190003800466	六角头螺栓	Bolt	12	
10	VG1500040023	气缸盖主螺栓	Bolt	24	
11	190003871252	1型六角螺母	Nut	4	
12	190014040007	平垫圈	Washer	4	
13	190003813467	双头螺柱	Stud	2	
14	190003813429	双头螺柱	Stud	2	
15	VG1500040106	出水管接管垫片	Gasket	1	
16	VG1500060045	管接头组件	Nozzle assembly	1	
17	VG1500040104	出水管	Tube	1	

2.1.08 气缸盖/Cylinder Head

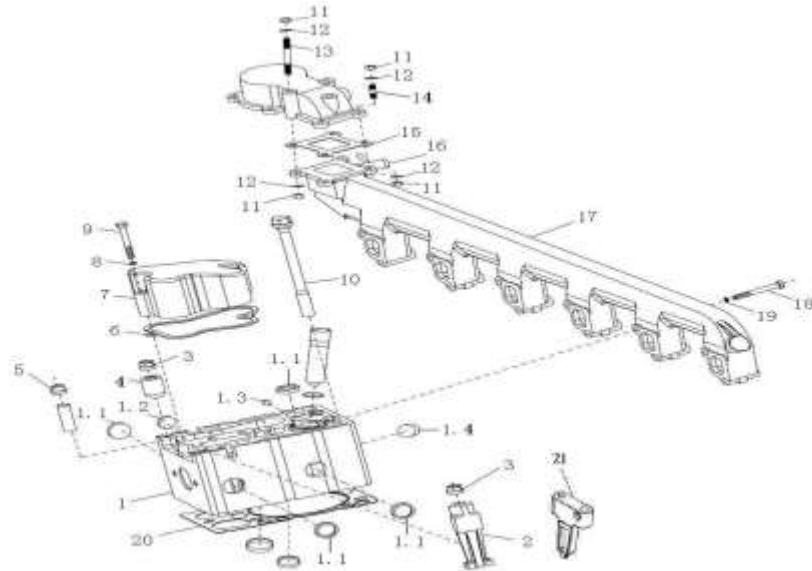

2.1.08 气缸盖/Cylinder Head

序号	零部件图号	名称	Part Name	数量	备注
No.	Part No.			Qty	Remark
18	190003800466	六角头螺栓	Bolt	12	
19	190003932023	波形弹性垫圈	Wave washer	12	
20	VG1500040049	气缸盖衬垫	Gasket	6	
21	VG1500040009	夹紧块	Block	5	

6	VG2130050065	气门间隙调整螺母	Nut	12	
7	VG14050119	气门摇臂座	Rocker bracket	6	
8	190003802655	六角头螺栓	Screw	12	
9	VG14050048	进气门摇臂	Rocker of intake valve	6	
10	VG1500050105	气门帽	Valve cap	12	
11	VG1500050025	气门锁夹	Valve cone	24	
12	VG1500050109	气门弹簧上座	Spring seat - upper	12	
13	VG1500050002	气门外弹簧	Valve spring (outside)	12	
14	VG1500050001	气门内弹簧	Valve spring (inside)	12	
15	VG1560050041	排气门用于47、69机	Exhaust valve for WD615.4	6	
16	VG1560051001	进气门	Inlet valve	6	
17	VG14050017	进气门弹簧下座	Spring seat - lower	6	

2.1.09 配气机构/Valve-Gear Mechanism

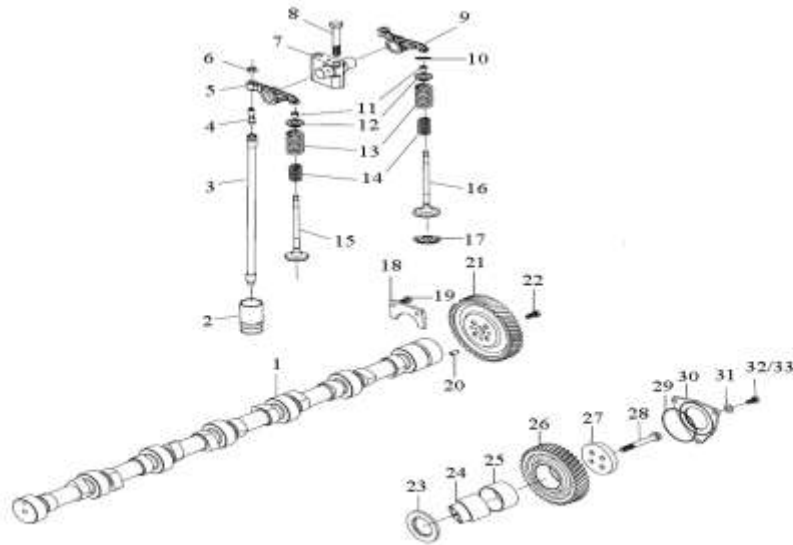

2.1.09 配气机构/Valve-Gear Mechanism

序号 No.	零部件图号 Part No.	名称	Part Name	数量 Qty	备注 Remark
18	VG14050133	凸轮轴止推片	Flange	1	
19	190003802399	六角头螺栓	Screw	2	
20	190003901409	圆柱销	Cylinder pin	1	
21	VG14050053	凸轮轴正时齿轮	Timing gear	1	
22	190003802443	六角头螺栓	Screw	4	
23	VG1540059032	中间齿轮垫片	Washer	1	
24	VG1540059031	中间齿轮轴	Shaft	1	
—	VG1560050053	中间齿轮总成	Middle gear ass.	1	Incl. 25~26
25	VG1560050054	衬套	Bush	1	
26	VG1560050052	中间齿轮	Gear	1	
27	VG1560050045	挡板	Plate	1	
28	VG1560050059	六角头螺栓	Screw	4	
29	190003120602	密封圈	Sealing ring	1	
30	VG1560050046A	盖板	Cover	1	

31	190003932023	波形弹性垫圈	Spring washer	3	
32	190003813414	双头螺柱	Stud	2	
33	190003862419	内六角圆柱头螺钉	Screw	1	

2.1.10 冷却系统/Cooling System

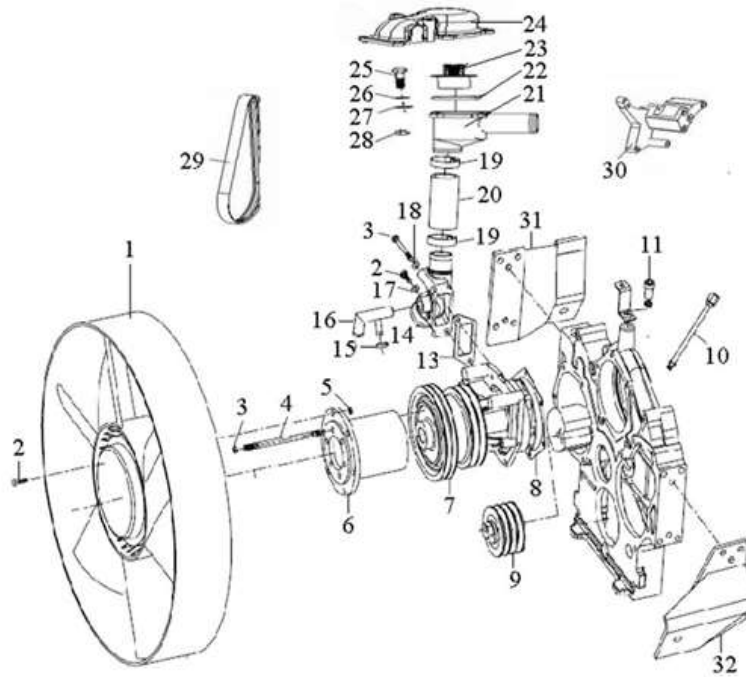

2.1.10 冷却系统/Cooling System

序号 No.	零部件图号 Part No.	名称	Part Name	数量 Qty	备注 Remark
1	VG2600060446	Φ640环形风扇（刚性）	Rigid fan-Φ640	1	
2	190003802424	六角头螺栓	Screw	7	
3	190003888452	锁紧螺母	Nut	6	
4	190003813148	双头螺柱（刚油风扇用）	Stud for Rigid fan	6	
5	190003888451	锁紧螺母	Nut	6	
6	VG1500060240	中间法兰（刚性风扇用）	Flange for Rigid fan	1	
7	VG1500060051	水泵总成	Water pump assembly	1	
8	VG140608	水泵密封垫	Gasket	1	
9	VG2600060313	自动张紧轮	Tensioning roller	1	
10	VG2600060460	水泵加黄油装置	Grease nozzle	1	
11	Q218B1625	内六角圆柱头螺钉	Screw	1	
13	VG14060024	水管接头垫片	Gasket	1	
14	VG1560060023	水管接头	Connector	1	
15	190003989336	软管卡箍	Hose clip	4	

16	VG1560060004	回水管接头组件	Pipe connecting piece	1	
17	190003932023	波形弹性垫圈	Spring washer	2	
18	190014070002	小垫圈	Washer	1	
19	190003989308	软管卡箍	Hose clip	2	
20	VG61000060276	胶管	Rubber pipe	1	
21a	VG1047060001/1	调温器总成 (80度)	Thermostat ass.80°c	1	Incl. 21-28

2.1.10 冷却系统/Cooling System

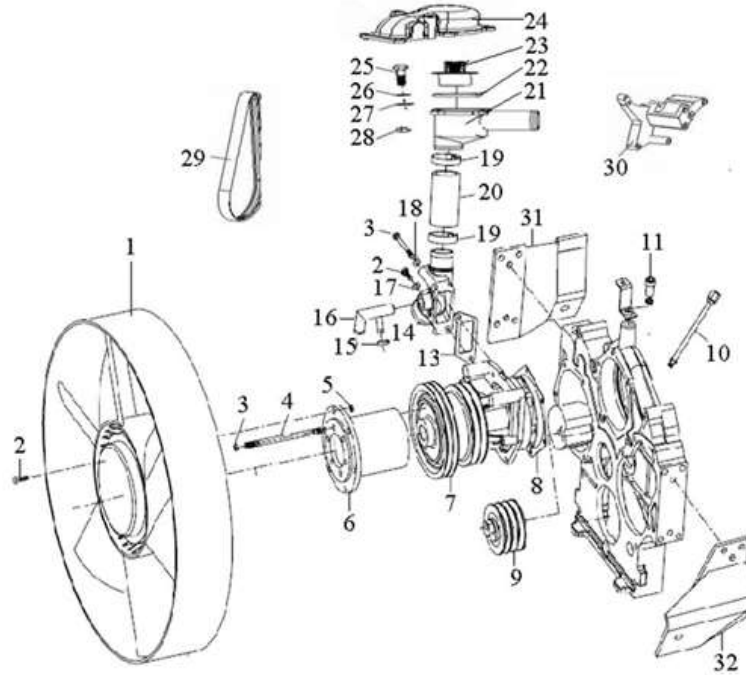

2.1.10 冷却系统/Cooling System

序号	零部件图号	名称	Part Name	数量	备注
No.	Part No.			Qty	Remark
21b	VG1047060001/2	调温器总成 (80度)	Thermostat ass.80°c	1	Inc 21-28
21.1	VG1500061203	节温器壳体	Housing	1	for 21a
21.1	VG1095061204	节温器壳体	Housing	1	for 21b
22	VG1047060004	水封圈	Washer	1	for 21a
22	VG1047060014	水封圈	Washer	1	for 21b
23	VG1047060002	节温器芯 (80度)	Thermostat core 80°c	1	for 21a
23	VG1047060012	节温器芯 (80度)	Thermostat core 80°c	1	for 21b
24	VG1500040105	出水管接管	Pipe	1	
25	Q150B0830	六角头螺栓	Screw	4	
26	Q40308	弹簧垫圈	Spring washer	4	
27	Q40108	平垫圈	Washer	4	
28	Q340B08	1型六角螺母	Nut	4	
29	VG1069020010	汽车多楔带(水泵皮带)	Belt for water pump	1	
30	VG1500130018A	空调托架	Bracket for air conditioner	1	
31	VG1095060009	右支架	Bracket -right	1	
32	VG1095060006	左支架	Bracket -left	1	

2.1.11 机油泵和机油滤清器/Oil Pump and Oil Filter

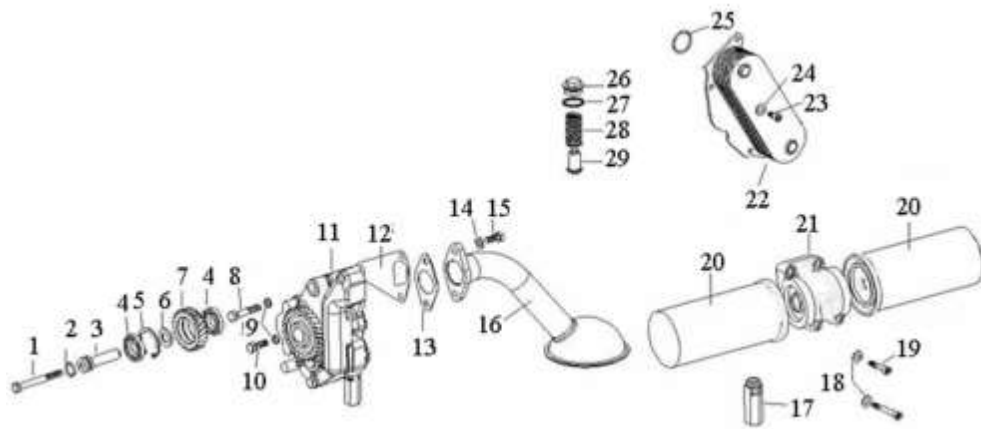

2.1.11 机油泵和机油滤清器/Oil Pump and Oil Filter

序号 No.	零部件图号 Part No.	名称	Part Name	数量 Qty	备注 Remark
1	190003802578	六角头螺栓	Screw	1	
2	VG14070155	密封圈	Washer	1	
3	VG14070056	中间齿轮轴	Shaft	1	
4	190003311410	向心球轴承	Ball bearing	2	
5	190003934732	带凸齿的孔用挡圈	Ring	1	
6	VG14070049	中间隔圈	Ring	1	
7	VG14070061	机油泵中间齿轮	Gear	1	
8	190003800551	六角头螺栓	Screw	1	
9	190003931122	弹簧垫圈	Spring washer	2	
10	190003802527	六角头螺栓	Screw	1	
11	VG1500070021	45mm加宽机油泵	Oil pump	1	
11,01	VG14070060	机油泵驱动齿轮	Gear	1	
11,02	VG1500070029	机油泵前盖	Cover -front	1	
11,03	VG1500070015	机油泵壳体	Housing	1	
11,04	VG1500070024	机油泵后盖	Cover -rear	1	
11,05	VG1047070203	机油泵齿轮总成	Gear	1	
11,06	VG1047070204	机油泵齿轮总成	Gear	1	
11,07	VG1560070099	机油泵限压阀总成	Pressure limit valve	1	
11,08	VG1047070201	衬套	Bush	4	
11,09	Q150B1085	六角头螺栓	Screw	1	
11,10	Q340B10	六角螺母	Nut	1	
11,11	Q150B1075	六角头螺栓	Screw	4	

2.1.11 机油泵和机油滤清器/Oil Pump and Oil Filter

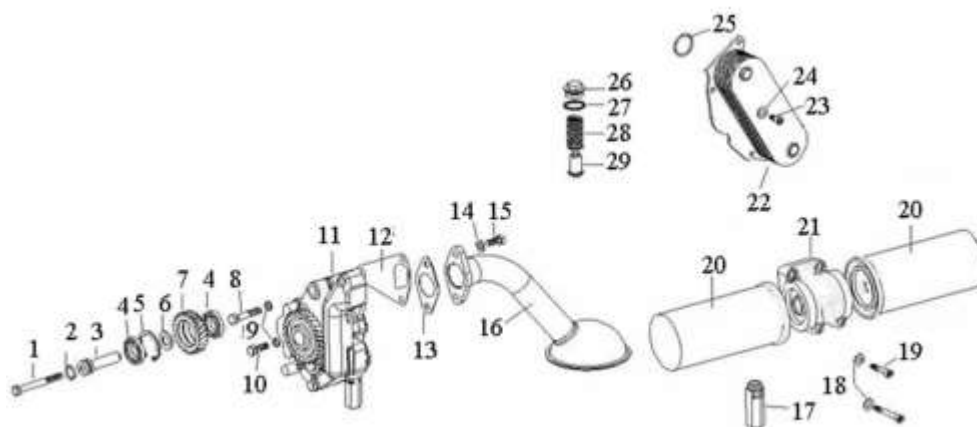

2.1.11 机油泵和机油滤清器/Oil Pump and Oil Filter

序号 No.	零部件图号 Part No.	名称	Part Name	数量 Qty	备注 Remark
11,12	Q5210820	圆柱销	Cylinder pin	6	
11,13	Q150B1045	六角头螺栓	Screw	1	
11,14	Q218B1070	内六角螺栓	Screw	1	
12	VG14070055	机油泵垫片	Gasket	1	
13	VG140778	垫片	Gasket	1	
14	190003932025	鞍形弹性垫圈	Spring washer	2	
15	190003802523	六角头螺栓	Screw	2	
16	VG1800070054	集滤器总成	Suction pipe	1	
17	VG1500070097	主油道限压阀总成	Pressure limit valve	1	
18	190003932023	波形弹性垫圈	Spring washer	4	
19	190003862443	内六角圆柱头螺钉	Screw	2	
20	VG61000070005	旋装式机油滤芯总成	Oil filter	2	
21	VG1500070051	机油滤清器底座组件	Oil filter base asse.	1	
22	VG1500010334	机油冷却器(8片)	Oil radiator	1	
23	190003862419	内六角圆柱头螺钉	Screw	4	
24	190003932023	波形弹性垫圈	Spring washer	4	
25	VG1400010032	密封圈	Washer	2	
26	190003962051	轻型六角头圆柱螺塞	Plug	1	
27	VG2600010735	复合垫圈	Washer	1	
28	VG14070068	安全阀弹簧	Spring-for safety valve	1	
29	VG14070069	安全阀	Safety valve	1	
	VG1540110212	支撑块	Support block	2	

2.1.12 供油系/Fuel Supply System

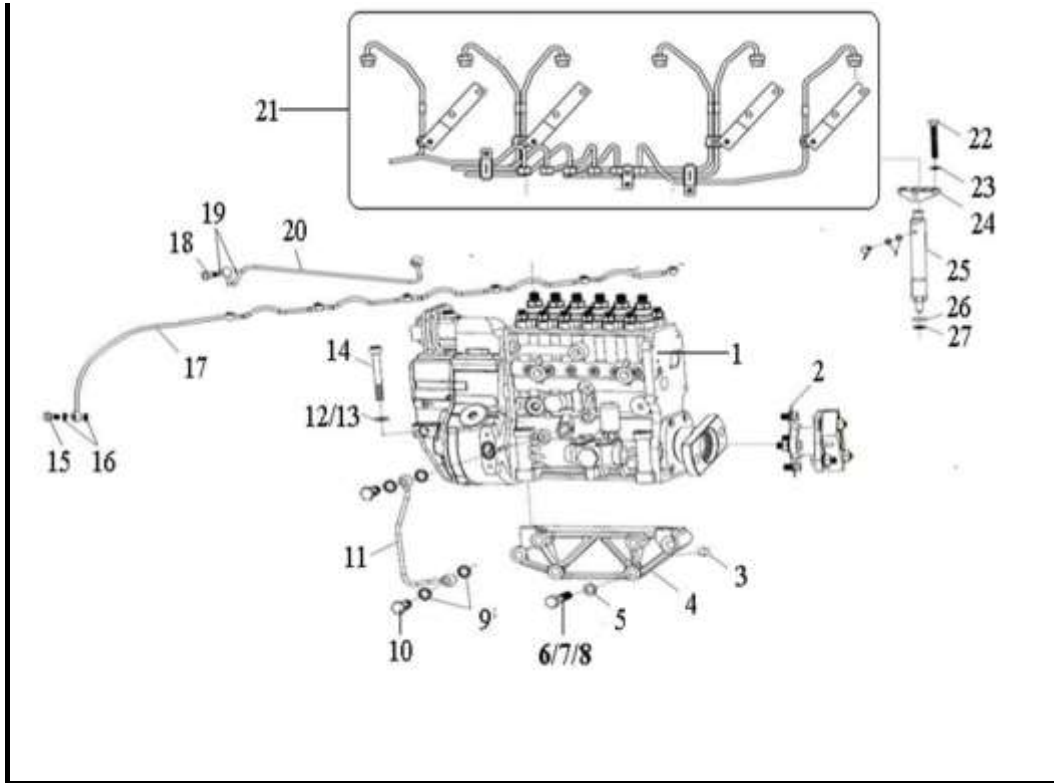

2.1.12 供油系/Fuel Supply System

序号 No.	零部件图号 Part No.	名称	Part Name	数量 Qty	备注 Remark
1	VG1560080022	喷油泵带K型调速器 69	Fuel injector pump for WD615.69	1	
1,1	VG1500080100	输油泵总成配87/69泵	Fuel delivery pump for WD615.87/69	1	
2	VG1560080300	联轴器总成	Coupling ass.	1	
2,01	VG1560080279	联轴器法兰组件	Coupling flange	1	
2,02	VG1560080219	弹性连接片	Flexible driving plate	12	
2,03	VG1560080273	衬套	Bush	8	
2,04	Q40012T16F9	小垫圈	Washer	8	
2,05	VG1560080271	垫圈	Washer	8	
2,06	Q150B1250TF2	六角头螺栓	Screw	2	
2,07	Q150B1235TF2	六角头螺栓	Screw	4	
2,08	Q150B1240TF2	六角头螺栓	Screw	2	
2,09	Q340B12T13F2	1型六角螺母	Nut	8	
2,10	VG1560080266	法兰	Flange	2	
2,11	VG1560080270	连接管	Connecting tube	1	
2,12	VG1560080194	角度调节板	Angle regulator plate	1	
2,13	VG1560080001	六角头螺栓	Screw	1	
3	190003901600	圆柱销	Cylinder pin	2	
4	VG1500080174	喷油泵托架	Bracket	1	

2.1.12 供油系/Fuel Supply System



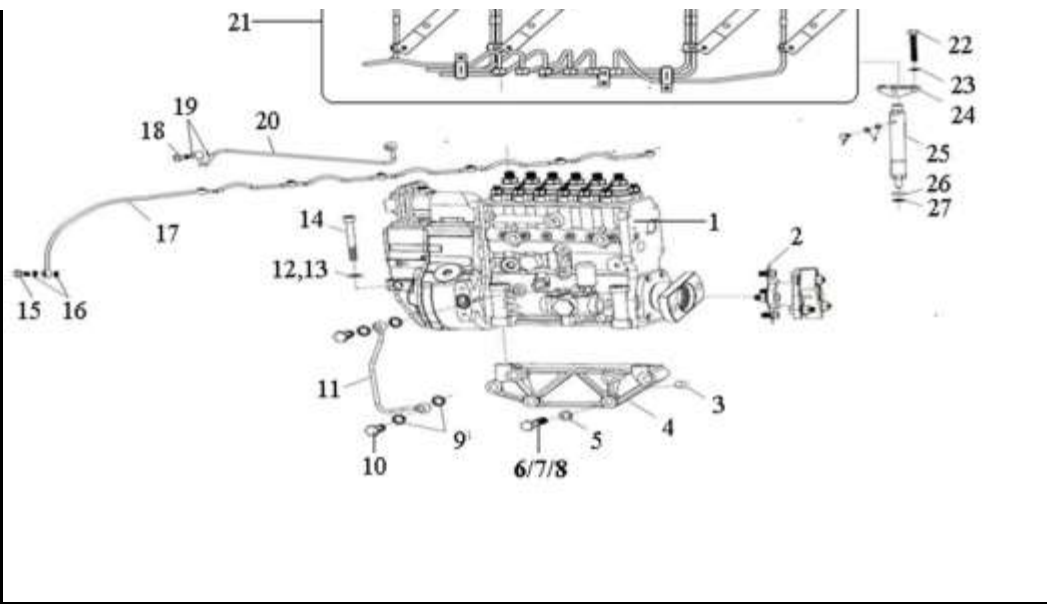

2.1.12 供油系/Fuel Supply System

序号 No.	零部件图号 Part No.	名称	Part Name	数量 Qty	备注 Remark
5	190003931142	弹簧垫圈	Spring washer	6	
6	Q150B1295	六角头螺栓	Screw	3	
7	Q150B1285	六角头螺栓	Screw	1	
8	Q150B1245	六角头螺栓	Screw	2	
9	VG2600080200	密封垫圈	Washer	14	
10	190003962621	空心螺栓	Female screw	7	
11	VG1560070025	润滑油回油管总成	Oil return tube	1	
12	190003930271	平垫圈	Washer	4	
13	VG18872339	自锁垫圈	Washer	4	
14	190003800571	六角头螺栓	Screw	4	
15	VG1500080090	空心螺栓	Female Screw	6	
16	VG9003080001	复合密封垫圈	Washer	12	
17	VG1500080095	回油管总成	Fuel return line	1	
18	190003962612	空心螺栓	Female screw	1	
19	VG9003080004	复合密封垫圈	Washer	2	
20	VG1560080284	空气管	Air pipe	1	
21	VG1560080278A	高压油管组	Injection pipe	1	
22	VG2600080383	六角头螺栓	Screw	12	
23	190003932023	波形弹性垫圈	Spring washer	12	
24	VG1500080094A	紧固压板	Plate	6	

2.1.12 供油系/Fuel Supply System

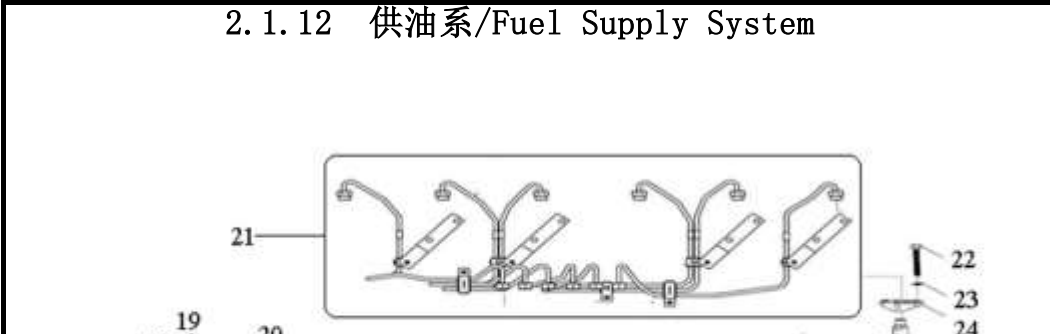

2.1.13 燃油滤清器部分(M+H)/Fuel Filter

序号 No.	零部件图号 Part No.	名称	Part Name	数量 Qty	备注 Remark
0	VG14087295A	燃油滤清器总成	fuel precision filter ass.	1	
1	VG1560080011	旋装式燃油精滤器总成	fuel precision filter ass.	1	
1,1	VG1560080012	旋装式燃油精滤器	fuel precision filter	1	
1,2	VG1560080013	旋装式燃油精滤器滤座	Base	1	
1a	190003802527	六角头螺栓	Screw	2	
1b	190003931122	弹簧垫圈	Spring washer	2	
1c	190003935009	平垫圈	Washer	2	
1d	190003802523	六角头螺栓	Screw	2	
1e	190003932024	波形弹性垫圈	Spring washer	2	
1f	190003930012	大垫圈	Washer	2	
1g	VG14080739A	旋装式柴油细滤芯	fuel precision filter	1	
2	VG1560080016	旋装式燃油粗滤器总成	Fuel preliminary filter ass.	1	
2,1	VG1560080014	旋装式燃油粗滤器滤座	Base	1	
2,2	VG1047080011	滤芯和滤杯总成	Filter and cup	1	
2,2.1	VG1540080311	旋装式燃油粗滤器	Fuel preliminary filter	1	
2,2.2	VG1047080009	燃油粗滤器水杯	Cup	1	
2a	190003802532	六角头螺栓	Screw	2	
2b	190003931122	弹簧垫圈	Spring washer	2	
2c	190003935009	平垫圈	Washer	2	
2d	VG14080740A	旋装式燃油粗滤芯	Fuel preliminary filter	1	
3	VG1092080019	燃油管总成	Fuel pipe	1	
4	VG1092080017	燃油管总成	Fuel pipe	1	
5	VG1092080018	燃油管总成	Fuel pipe	1	
5a	VG2600080200	密封垫圈	Washer	4	
6	VG1092080026	燃油精滤器托架	Bracket	1	
7	VG1540080027	粗滤支架	Bracket	1	
	VG1047080015	燃油粗滤器护套	Protective sleeve	1	

2.1.14 电机及传感器/Alternator、Starter & Sensor

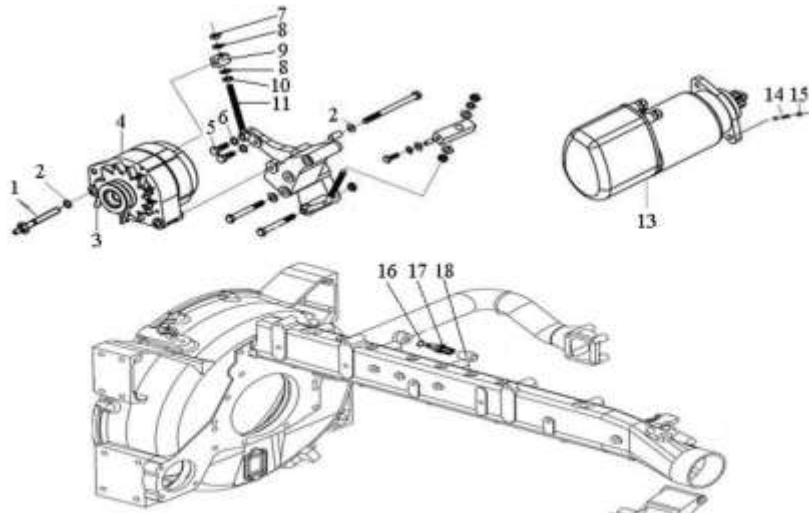

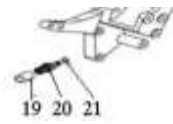

2.1.14 电机及传感器/Alternator、Starter & Sensor

序号 No.	零部件图号 Part No.	名称	Part Name	数量 Qty	备注 Remark
1	VG1092094001	发电机双头螺栓	Screw	1	
2	190003932025	鞍形弹性垫圈	Spring washer	1	
3	VG2600020258	发电机多楔带	Belt	1	
4	VG1095094002	1540W交流发电机	Alternator	1	
5	Q150B1055	六角头螺栓	Screw	1	
6	190003930271	平垫圈	Washer	1	
7	190003888452	螺母	Nut	1	
8	190003930271	平垫圈	Washer	2	
9	VG1500090045	拉紧块	Block	1	
10	VG1500090048	1型六角螺母	Nut	1	
11	VG1500090046	拉紧螺栓	Screw	1	
12	VG2600090288	压紧块	Blocket	1	
13	VG1560090001	减速型起动机	Starter	1	
14	190003813532	双头螺柱	Stud	3	
15	190003888452	螺母	Nut	3	
16	VG9003080005	复合密封垫圈	Washer	1	
17	VG1500090061	水温表传感器	Water temperature sensor	1	
18	VG2600090318	水温传感器罩	Cover	1	
19	VG1095090139	机油压力传感器罩	Cover	1	
20	VG1092090311	电子机油压力传感器	Oil pressure sensor	1	
21	VG2600080275	复合密封垫圈	Washer	1	

2.1.15 进排气系统/ Intake and Exhaust Manifold

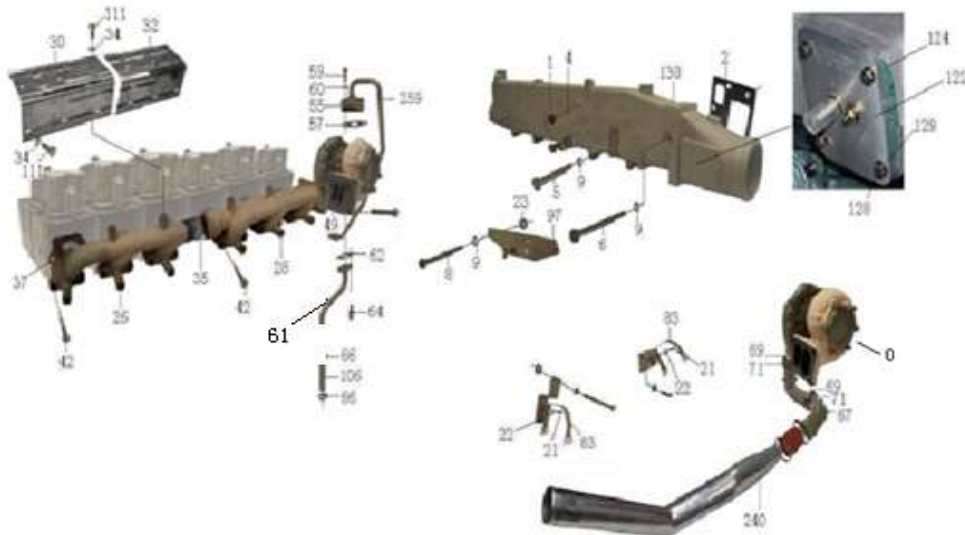

2.1.15 进排气系统/ Intake and Exhaust Manifold					
序号	零部件图号	名称	Part Name	数量	备注
No.	Part No.			Qty	Remark
0	VG1560118229	废气涡轮增压器	Turbo supercharger	1	
1	190003962014	六角头螺塞	plug	1	
2	VG1500110024	进气管垫片	Intake tube gasket	6	
4	VG9003080003	复合密封垫圈	Sealing washer	1	
5	190003800465	六角头螺栓	Screw	6	
6	VG14110064	进气管紧固螺栓	Screw	4	
8	190003800497	六角头螺栓	Screw	2	
9	190003932023	波形弹性垫圈	Spring washer	12	
21	190003802411	六角头螺栓	Screw	2	
22	190003932023	波形弹性垫圈	Spring washer	2	
23	VG609E110036	调整垫圈	Adjust washer	6	
25	190003932023	波形弹性垫圈	Spring washer	2	
26	VG2600111137	前排气歧管	Exhaust manifold - front	1	
28	VG2600111136	后排气歧管	Exhaust manifold - rear	1	
30	VG2600111142	前隔热罩	Cover - front	1	
32	VG2600111143	后隔热罩	Cover - rear	1	
34	190003937282	大垫圈	Washer	12	
35	VG260110162	排气管密封环	Exhaust tube sealing ring	4	
37	VG1560110111A	排气管垫片	Exhaust tube gasket	6	
42	VG2600111052	排气管紧固螺栓	Screw	12	
46	190003888470	自锁螺母	nut	4	
49	VG1560110210	增压器密封垫	Turbo supercharger sealing gasket	1	
55	VG1560110152	进油管法兰	Flange	1	

2.1.15 进排气系统/ Intake and Exhaust Manifold

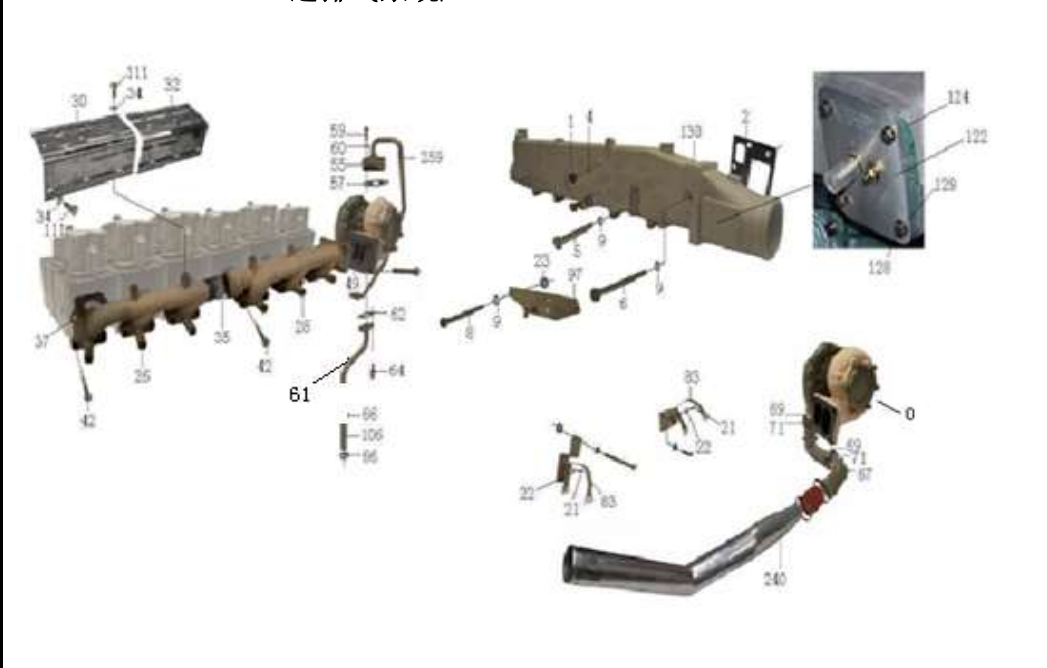

2.1.15 进排气系统/ Intake and Exhaust Manifold

序号	零部件图号	名称	Part Name	数量	备注
----	-------	----	-----------	----	----

No.	Part No.	名称	Part Name	Qty	Remark
57	VG609E110050	进油管垫片	Gasket	1	
59	190003862428	内六角圆柱头螺钉	Screw	2	
60	VG188250083	自锁垫圈	Washer	4	
61	VG1560079003	回油管总成	Pipe - oil return	1	
62	VG2600110048	回油管法兰垫片	Washer	1	
64	VG1460070014	回油管螺栓	Screw	2	
66	190003989340	软管卡箍	Hose clip	2	
67	VG1800110045	连接弯管	Connecting tube	1	
—	VG2600111078	连接弯管	Connecting tube	1	
69	VG1560110226	夹子	Clip	2	
71	VG190320035	密封圈	Washer	2	
83	VG1560110021	卡箍带	Clamp	2	
85	VG1700550013	张紧销	Pin	2	
87	VG209190017	拉紧销	Pin	2	
93	190003932023	波形弹性垫圈	Spring washer	2	
94	190003802419	六角头螺栓	Screw	4	
95	190003802415	六角头螺栓	Screw	2	
96	190003932023	波形弹性垫圈	Spring washer	6	
97	VG9100570019	悬臂总成	bracket ass.	1	
99	VG9100570018	悬臂	bracket	1	
100	VG9100570017	弯板	plate	1	
101	VG9000570035	轴销	shaft pin	1	
106	VG2600070071	增压器回油用软管	Supercharger oil return hos	1	

2.1.15 进排气系统/ Intake and Exhaust Manifold

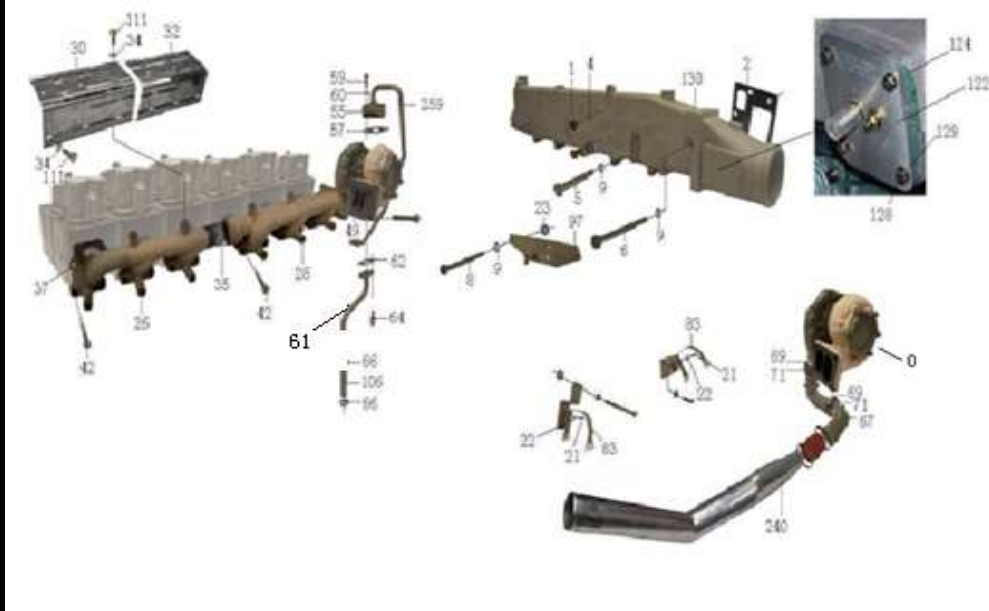

2.1.15 进排气系统/ Intake and Exhaust Manifold

序号	零部件图号	名称	Part Name	数量	备注
No.	Part No.			Qty	Remark
111	VG1500110963	耐热螺栓	Screw	12	
113	VG2600110668	增压器排气口堵盖	Cover	1	

122	VG2600110458	进气管盖板	Cover	1	
124	VG2600110457	进气管盖板垫片	Gasket	1	
128	190003802331	六角头螺栓	Screw	4	
129	190003932008	波形弹性垫圈B6	Washer	4	
130	VG2600110812	进气管总成(带进气管电加热系统)	Intake manifold ass.	1	
132	VG2600110688	进气管	Intake manifold	1	
133	VG2600110455	盖板	Cover	1	
136	VG2600110456	垫片	Gasket	1	
139	190003931102	弹簧垫圈	Spring washer	3	
140	190003802432	六角头螺栓	Screw	3	
163	VG2600111429	双头螺柱	Stud	4	
183	VG9003980003	强力卡箍	Clip	2	
195	AZ9003862462	内六角圆柱头螺钉	Screw	2	
200	190003802411	六角头螺栓	Screw	2	
209	VG29108B	堵盖	Cover	2	
211	VG29129A	堵盖	Cover	1	
218	VG29130A	堵盖	Cover	1	
229	VG1034110100	卡箍	Clip	1	
231	Q33408	1型全金属六角锁紧螺母	Nut	1	
232	Q150B0855	六角头螺栓	Screw	1	
233	Q40108	平垫圈	Washer	1	

2.1.15 进排气系统/ Intake and Exhaust Manifold

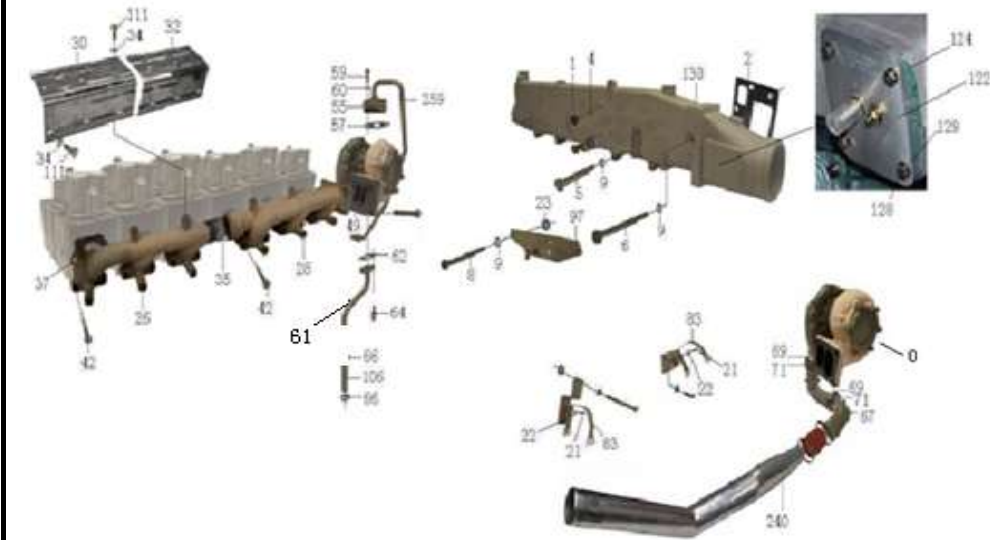

2.1.15 进排气系统/ Intake and Exhaust Manifold

序号	零部件图号	名称	Part Name	数量	备注
No.	Part No.			Qty	Remark
234	Q40308	弹簧垫圈	Spring washer	1	
240	VG1047110104	中冷管	Intercooling tube	1	
244	VG1047110103	硅胶管	Hose	1	
248	VG1047110102	支架	Bracket	1	
255	VG1047110105	固定板	Plate	1	

8	190003962607	空心螺栓	Female Screw	1	
9	VG1560060012	空压机进水管接头	Connection - water intake	1	
10	VG2600080200	密封垫圈	Washer	1	
11	Q351B14	六角薄螺母	Nut	1	
12	190003989336	软管卡箍	Hose clip	4	
13	VG1560060019	国II空压机进水管	Pipe - water intake	1	
14	VG2600130026	水冷空压机水管接头	Connection	2	
15	VG1560130035	空压机进气管接头	Connection - air intake	1	
16	190003559778	六角螺母	Nut	1	
17	VG1560060018	空压机出水管	Pipe - water outtake	1	
18	Q1860830TF2	六角法兰面螺栓	Screw	7	
19	VG1560130064	喷油泵齿轮	Gear	1	
20	VG409020045	垫片	Shim	1	
21	VG2600130045	六角螺母	Nut	1	
	VG2600130037	垫圈	Washer	1	

2.1.16 双缸空压机/Compressor

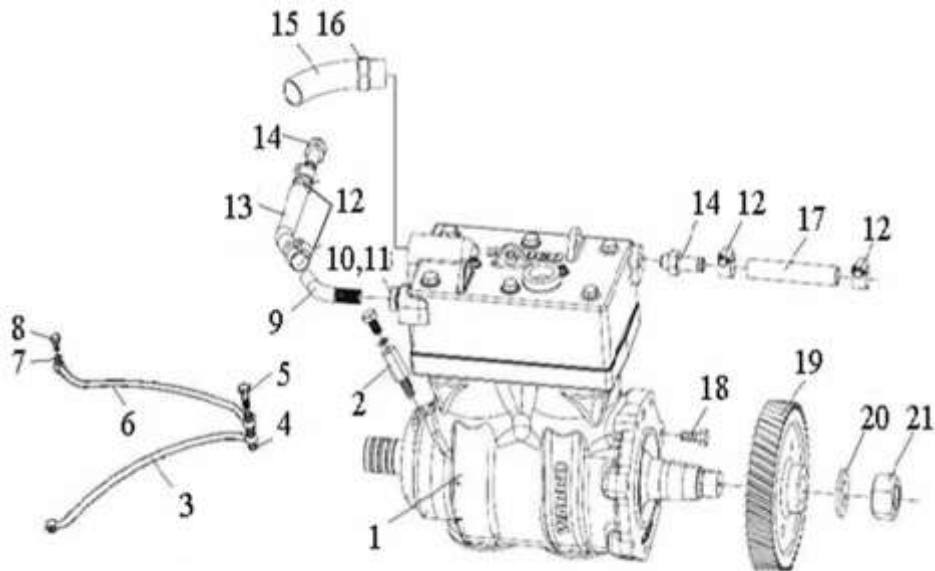

2.1.16 双缸空压机/Compressor

序号 No.	零部件图号 Part No.	名称	Part Name	数量 Qty	备注 Remark
	VG9003080003	复合密封垫圈	Sealing washer	2	
	VG2600080200	密封垫圈	Sealing washer	2	
	Q150B0875	六角头螺栓	Screw	1	
	Q150B0885	六角头螺栓	Screw	1	
	Q40308	弹簧垫圈	Spring washer	2	

